



# Bronze Ball Valve For Potable Water

## Two-Piece • Standard-Port

### Blow-Out Proof Stem

### 600 PSIG WOG

### Solder Ends

# UPBA150/150S 1/2" - 2"



WQA tested and Certified against WQA ORD0902 for California "lead free" compliance.

Dimensions and workmanship conform to MSS SP-110  
Designed in accordance with the requirements of California AB 1953 and Vermont S 152

#### MATERIALS LIS

ITEM	PART	MATERIALS	ASTM SPEC.
1	Body	Cast Bronze	B584 C89833
2	Tailpiece	Brass	B283 C69300
		Cast Bronze (1" & up)	B584 C89833
3	Ball	Brass w/ Hard Chrome Plating 316 Stainless Steel (1)	B283 C69300 A276
4	Seat	RPTFE, 15% Glass Filled	
5	Stem	Brass 316 Stainless Steel (1)	UNS C89833 A276
6	Thrust Washer	RPTFE, 25% Glass Filled	
7	Packing	PTFE	
8	Packing Nut	Brass	B16
9	Handle	Steel w/ Zinc Plating	B633
10	Hand Grip	Vinyl	
11	Handle Nut	Steel w/ Zinc Plating	B633

(1) Ball and stem are stainless for UPBA150S.

#### DIMENSIONS

	UNITS	1/2"	3/4"	1"	1-1/4"	1-1/2"	2"
A (DIA)	INCHES	0.50	0.76	0.88	1.06	1.31	1.56
	mm	12.7	19.3	22.4	26.9	33.3	39.6
B	INCHES	2.39	3.05	3.71	4.54	5.00	6.25
	mm	58.6	74.7	90.9	111.2	122.5	153.1
C	INCHES	1.07	1.56	1.76	2.27	2.50	3.13
	mm	26.2	38.2	43.1	55.6	61.3	76.7
D	INCHES	1.89	2.13	2.29	2.67	2.85	3.02
	mm	46.3	52.2	56.1	65.4	69.8	74.0
E	INCHES	3.81	4.56	4.56	6.31	6.31	7.19
	mm	93.3	111.7	111.7	154.6	154.6	176.2
F	TUBE SIZE Ø	.63	.88	1.13	1.38	1.63	2.13
Cv		13	35	38	61	87	121

Note: DN (Diameter Nominal) = Metric equivalent size.

Rev. 7

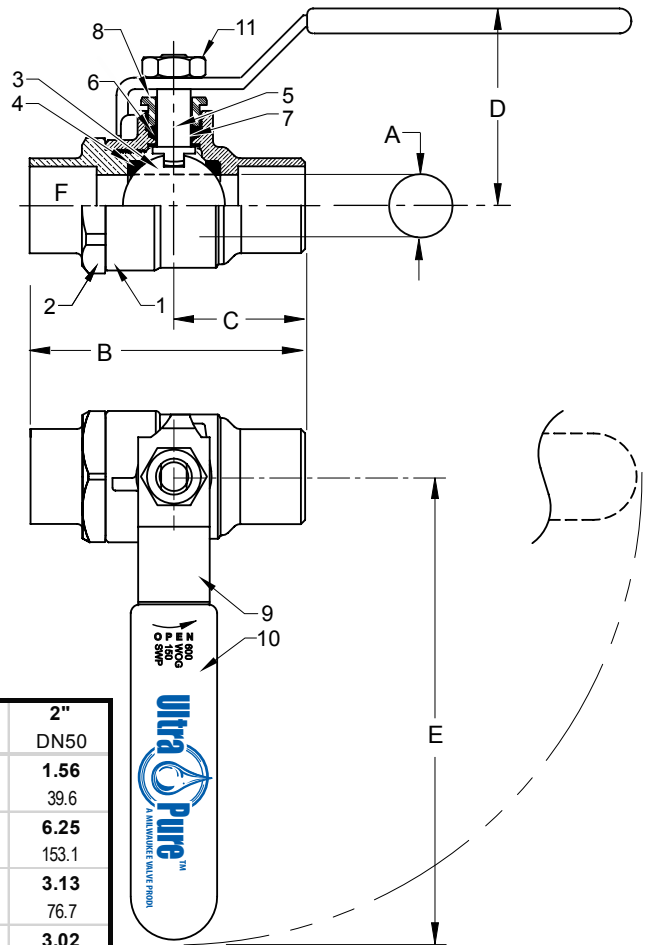

Milwaukee Valve Company  
16550 W. Stratton Drive  
New Berlin, WI 53151  
Phone: 262-432-2700  
Fax: 262-432-2701

**Note:** Lead free refers to the wetted surface of the pipe, fittings and fixtures in potable water systems that have a weighted average lead content ≤ 0.25%. Source: California Health and Safety Code (116875).

The information presented on this sheet is correct at the time of publication. Milwaukee Valve reserves the right to change design, and/or material specifications without notice. For the Installation, Operation and Maintenance Manual (IOM) see the engineering section on our website. For the most current information access [www.milwaukeevalve.com](http://www.milwaukeevalve.com)

