



Bronze Ball Valve For Potable Water

Two-Piece • Standard-Port

Blow-Out Proof Stem

600 PSIG WOG

Threaded Ends

UPBA100/100S 1/4" - 2"



WQA tested and Certified against WQA ORD0902 for California "lead free" compliance.

Dimensions and workmanship conform to MSS SP-110
Designed in accordance with the requirements of California AB 1953 and Vermont S 152

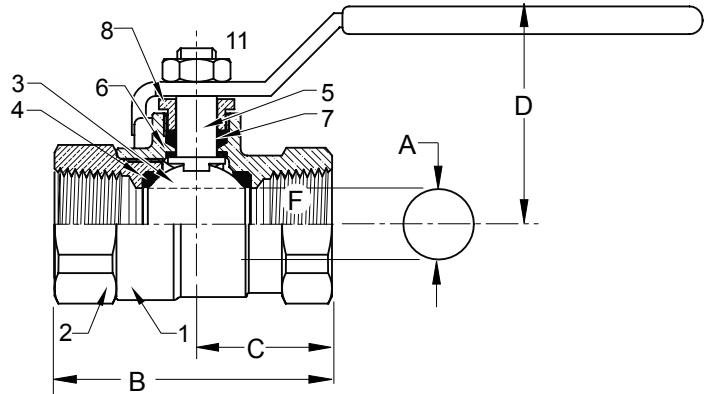

MATERIALS LIST

ITEM	PART	MATERIALS	ASTM SPEC.
1	Body	Cast Bronze	B584 C89833
2	Tailpiece	Brass	B283 C69300
		Cast Bronze (1" & up)	B584 C89833
3	Ball	Brass w/ Hard Chrome Plating	B283 C69300
		316 Stainless Steel (1)	A276
4	Seat	RPTFE, 15% Glass Filled	
5	Stem	Brass	UNS C89833
		316 Stainless Steel (1)	A276
6	Thrust Washer	RPTFE, 25% Glass Filled	
7	Packing	PTFE	
8	Packing Nut	Brass	B16
9	Handle	Steel w/ Zinc Plating	B633
10	Hand Grip	Vinyl	
11	Handle Nut	Steel w/ Zinc Plating	B633

(1) Ball and stem are stainless for UPBA100S.

DIMENSIONS

A (DIA)	UNITS	1/4"	3/8"	1/2"	3/4"	1"	1-1/4"	1-1/2"	2"
		DN6	DN10	DN15	DN20	DN25	DN32	DN40	DN50
B	INCHES	1.86	1.86	2.19	2.64	3.17	3.50	3.96	4.30
	mm	45.6	45.6	53.7	64.7	77.7	85.8	97.0	105.4
C	INCHES	1.00	1.00	1.10	1.30	1.58	1.74	1.97	2.15
	mm	24.5	24.5	27.0	31.9	38.7	42.6	48.3	52.7
D	INCHES	1.78	1.81	1.91	2.08	2.25	2.66	2.84	3.00
	mm	43.6	44.3	46.8	51.0	55.1	65.2	69.6	73.5
E	INCHES	3.81	3.81	3.81	4.56	4.56	6.31	6.31	7.19
	mm	93.3	93.3	93.3	111.7	111.7	154.6	154.6	176.2
F	THREAD SIZE	1/4" NPT	3/8" NPT	1/2" NPT	3/4" NPT	1" NPT	1-1/4" NPT	1-1/2" NPT	2" NPT
	Cv	7	7	13	30	38	61	87	121

Note: DN (Diameter Nominal) = Metric equivalent size.

Rev. 7

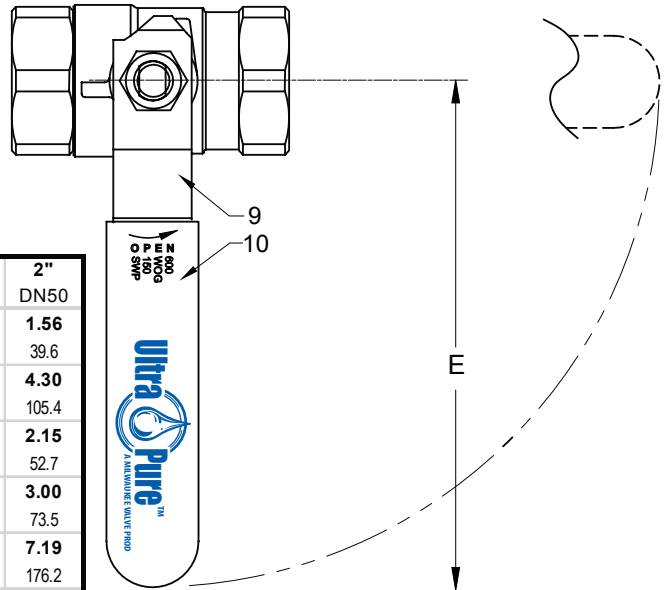

Milwaukee Valve Company
16550 W. Stratton Drive
New Berlin, WI 53151
Phone: 262-432-2700
Fax: 262-432-2701

Note: Lead free refers to the wetted surface of the pipe, fittings and fixtures in potable water systems that have a weighted average lead content ≤ 0.25%. Source: California Health and Safety Code (116875).

The information presented on this sheet is correct at the time of publication. Milwaukee Valve reserves the right to change design, and/or material specifications without notice. For the Installation, Operation and Maintenance Manual (IOM) see the engineering section on our website. For the most current information access www.milwaukeevalve.com

