



# GLOBE UP502 BRONZE

**300 lb. WOG†  
Potable Water Service  
Bronze Disc  
Threaded Bonnet  
Threaded Ends**

Dimensions and Workmanship Conform to MSS SP-80  
Designed in accordance with the requirements of California AB 1953  
and Vermont S 152



WQA tested and Certified against WQA ORD0902 for California "lead free" compliance.

1/4" to 1/2" sizes have the disc integral with the stem and have no disc ring.

### MATERIAL LIST

NO.	PART	MATERIAL	SPECIFICATION
1	Body	Bronze	ASTM B584 C89833
2	Bonnet	Bronze	ASTM B584 C89833
3	Disc	Bronze	ASTM B584 C89833
4	Stem	Bronze	ASTM B584 C89833
5	Disc Ring	Brass	ASTM B283 C69300 3/4" to 2"
6	Packing	Graphite	Commercial
7	Packing Nut	Brass	ASTM B 16
8	Handwheel	Mall. Iron	Commercial
9	Identification Plate	Aluminum	Commercial
10	Handwheel Nut	Brass	Commercial

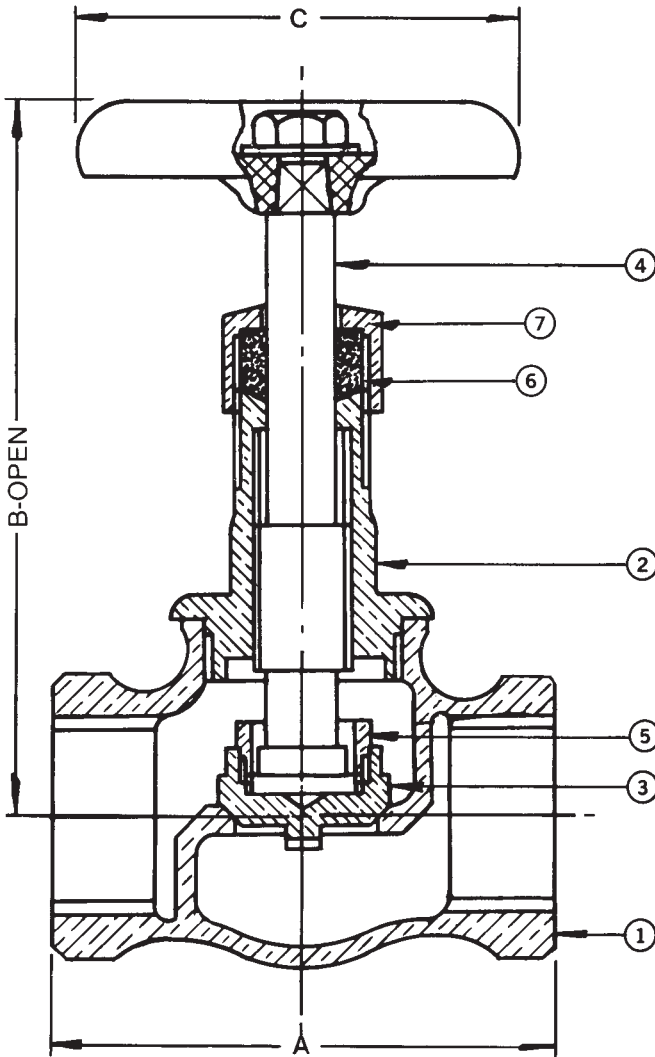

### DIMENSIONS - INCHES / MILLIMETERS

Units	Size	A	B	C	C <sub>v</sub>
Inches	1/4	1.63	3.06	2.00	1.16
mm	6.35	41.28	77.80	50.80	
Inches	3/8	1.81	3.19	2.00	2.21
mm	9.53	46.05	80.98	50.80	
Inches	1/2	2.31	3.63	2.25	3.64
mm	12.70	58.75	92.08	57.15	
Inches	3/4	2.56	3.94	2.50	6.65
mm	19.05	65.10	100.03	63.50	
Inches	1	2.94	4.38	2.75	11.10
mm	25.40	74.63	111.13	69.85	
Inches	1 1/4	3.38	5.19	3.13	20.00
mm	31.75	85.73	131.78	79.38	
Inches	1 1/2	3.69	5.75	3.50	28.00
mm	38.10	93.68	146.05	88.90	
Inches	2	4.44	6.75	4.00	48.00
mm	50.80	112.71	171.45	101.60	

† Non-Shock

Rev. 4

Milwaukee Valve Company  
16550 W. Stratton Drive  
New Berlin, WI 53151  
Phone: 262-432-2700  
Fax: 262-432-2701

**Note:** Lead free refers to the wetted surface of the pipe, fittings and fixtures in potable water systems that have a weighted average lead content  $\leq 0.25\%$ . Source: California Health and Safety Code (116875).

The information presented on this sheet is correct at the time of publication. Milwaukee Valve reserves the right to change design, and/or material specifications without notice. For the Installation, Operation and Maintenance Manual (IOM) see the engineering section on our website. For the most current information access [www.milwaukeevalve.com](http://www.milwaukeevalve.com)

